

FIBERGLASS DOOR SYSTEM

Installation Instructions for High Wind Velocity Areas



Thank you and congratulations. You have just purchased a premier fiberglass entry door system. If you have purchased an unfinished door system, we recommend that you paint/stain before installation. Refer to the finishing instructions section in this document. Please follow the instructions carefully for proper installation.

CAUTION: Some door units are heavy and may require two people to lift and install. Use proper lifting techniques and follow safe working practices.

Tools and materials needed:

Tape measure, Hammer, Square, Level, Wooden shims, 10d finish nails, #3 Phillips screwdriver, #8 x 3" Exterior grade screws, 3/16" x 3" & 3/16" x 3-3/4" Tapcon concrete screws for masonry substrate floor, Power drill with Phillips drill bit, Safety glasses, Caulking gun with quality exterior sealant, Putty

PARTS OF A DOOR SYSTEM

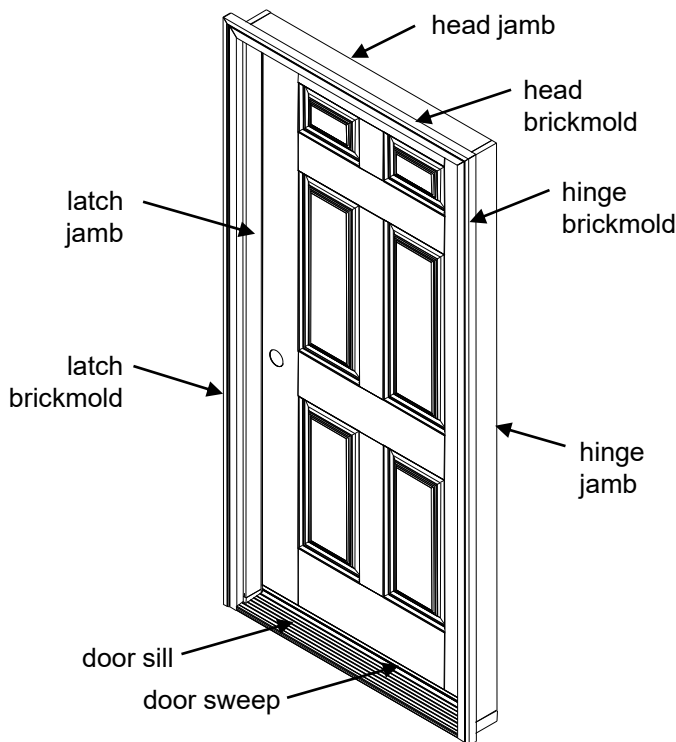

Before you begin:

1. Do not remove the plastic door plug until instructed to do so. This is used to keep the door system closed and aligned. If the door unit has handles on the latch and hinge jambs, remove them. Also, cover the door sill to protect against harmful particles or scratches during installation or between a long period of building construction and occupation. Note that any contact with wet cement or cement powder will damage the sill finish.
2. Make sure that the new door will properly fit in your frame opening. The recommended rough opening is 3/4" wider and 1/2" higher than the door prehung unit. Resize the opening if needed. Verify that the frame opening is level, square and plumb. It is important that the floor is level. Minor out of level conditions at the sides and top can be corrected by using shims but major misalignments need to be corrected before installation. Diagonal measurements must be equal to within 1/4" (as shown below). Note that the latch jamb should be adjusted for plumb so that the weatherstrip on the latch jamb is evenly compressed when the door is closed. Use a Carpenter's square and level to check that the frame opening is square, level and plumb.

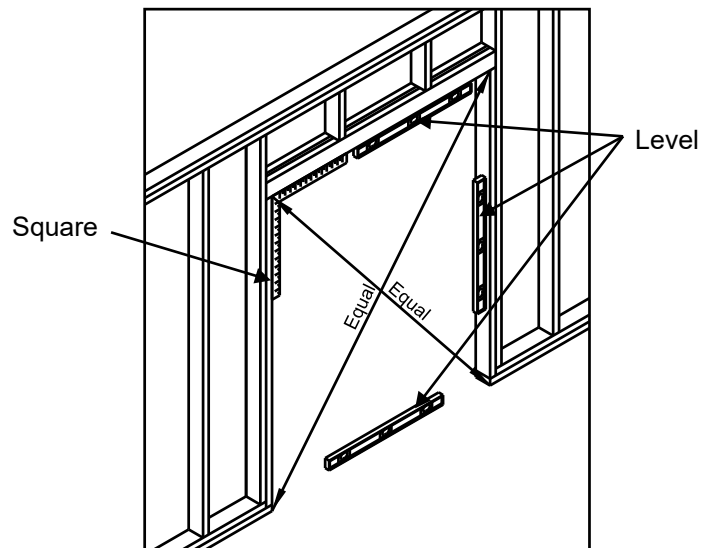

Important General Information

Buildings constructed prior to 1978 could contain lead paint which could be disturbed during window or door replacement. For more information on proper management of lead paint, go to: www.epa.gov/lead.

Contact local authorities or waste management company for proper recycling and disposal instructions for removed window or door.

1 INSTALLATION:

For anchoring details, please see pages 6 & 7.
For Florida and Texas, please see pg 8 for
installation drawings to be used for anchoring.

IMPORTANT: Before setting the door unit into the rough opening, apply generous beads of caulk to the underside of the door sill at locations shown in Figure 1a or 1b, including the plastic jamb adapter and brickmold. Make sure that at least 4 lines of bead seal the full width of the sill. Also apply a continuous and generous amount of bead of caulk to the back side of brickmolds as shown in figure 1c.

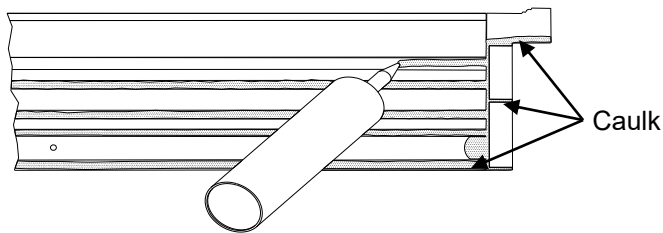

Figure 1a (In-swing)

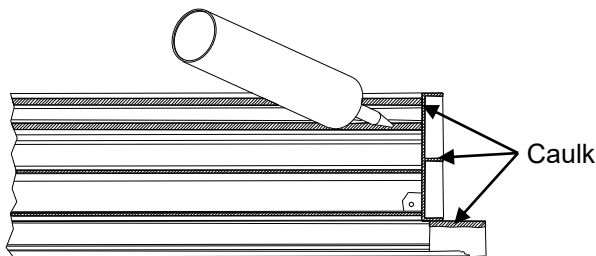

Figure 1b (Out-swing)

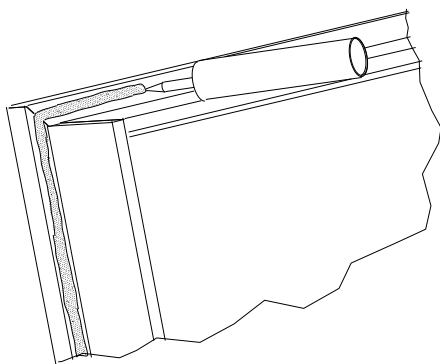

Figure 1c

2 For a single door, remove the bolt from the plastic door plug. From outside, set the door unit into the opening per Figure 2a. For a heavier door system, get help when lifting, setting and aligning.

From the inside, place a solid shim directly behind each hinge between the hinge jamb (or approx. same level as hinges on sidelite jamb) and opening frame per Figure 2b. Keep the door unit level, square and plumb on all four sides. Remove the plastic door plug completely.

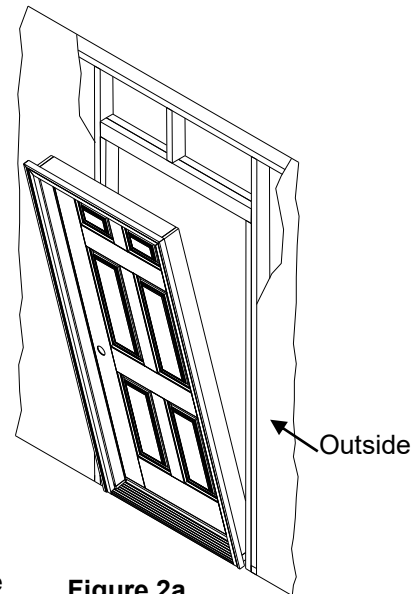

Figure 2a

Temporarily secure the door unit to the frame with two #8 x 3" screws or two 10d finish nails. Fasten at about 2" below the top hinge and 2" above the bottom hinge through the jamb and into the opening frame.

Make sure weatherstrip contact and margin are equal all around. Make further adjustments for level, square and plumb. Use 3 or 4 (8ft door) solid shims between the latch jamb and opening frame per Figure 2b. Additional shims may be used to keep the door aligned. Test to ensure proper operation of the door.

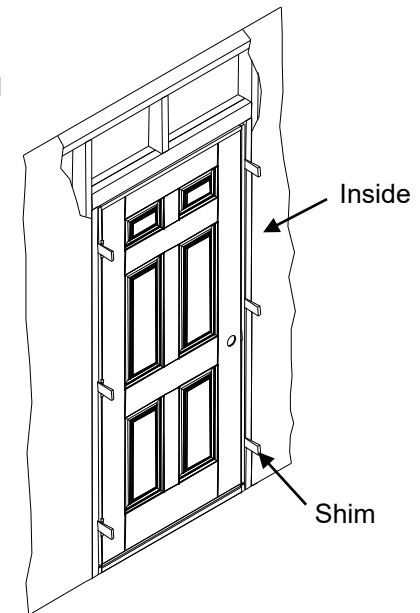

Figure 2b

Permanently fasten 3" exterior grade screws through the jambs into the shim and the frame per anchoring detail on page 6. Do not use drywall screws or nails. Do not over tighten the screws as it may cause jambs to bow. Remove excess shims and temporary fasteners.

Anchoring for Single Door with Sidelites

Shim above mullion per Figure 2c. Fasten 3" exterior grade screws (not included) through head jamb into the shim and the frame per anchor detail on page 7. Remove excess shim. Use wood screws for wood floor and Tapcon concrete screws for masonry floor.

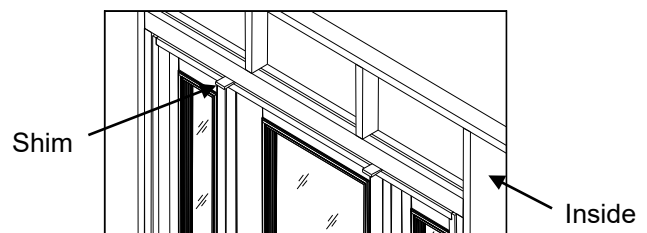

Figure 2c

Anchoring and Drilling for Double Door Units

Permanently fasten 3" exterior grade screws through the head jamb and side jambs into the frame at locations shown in anchoring detail on page 6. Use wood screws for wood floor and Tapcon concrete screws for masonry floor.

After checking to make sure that the double door is properly aligned, use the astragal bolts at the inactive door to mark and drill 3/8" diameter x 1-3/8" minimum deep holes through the head jamb and the sill per Figures 2d, 2e and 2f. Pre-drill 1/16" pilot holes for the mounting screws. Install the retaining plates (included) at both head jamb and sill. Use the #8x 2-1/4" screws included in the installation kit to mount the retaining plates.

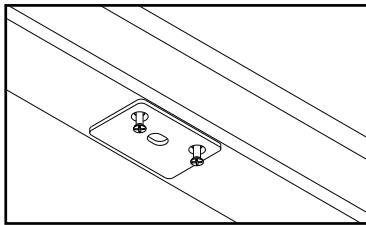

Figure 2d
(In-swing/Out-swing header)

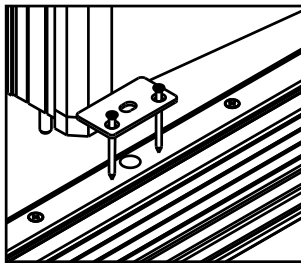

Figure 2e
(In-swing sill)

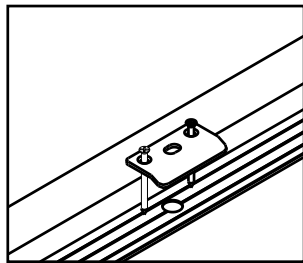

Figure 2f
(Out-swing sill)

- 3** Install 2 screws at the location shown in Figure 3 on the top hinge and 1 each on the lower 2 or 3 (8ft door) hinges (screws included in installation kit).

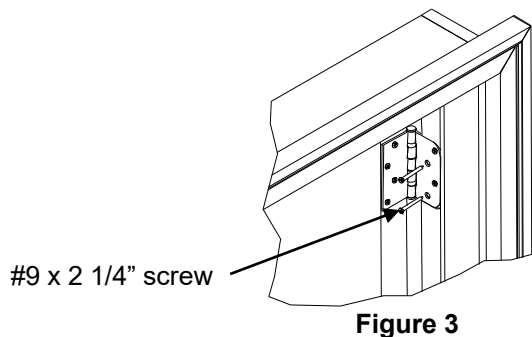

Figure 3

- 4** For the lockset hardware, use grade II latch and deadbolt. Shim the jamb behind the latch and deadbolt strike plates as needed and secure the strike plates to the jamb using #8x2" PFH wood screws. Make sure that the deadbolt engages fully. You should feel the bolt roll and click as it engages. If the bolt does not engage fully, you may need to deepen the strike bore.

For an in-swing door with adjustable threshold, adjust the threshold as shown in Figure 4 so that there is even contact between the door sweep and the threshold. To test, put a sheet of paper between door sweep and threshold, close the door and pull. The correct adjustment would have slight tension, but if the paper tears, the tension is too high.

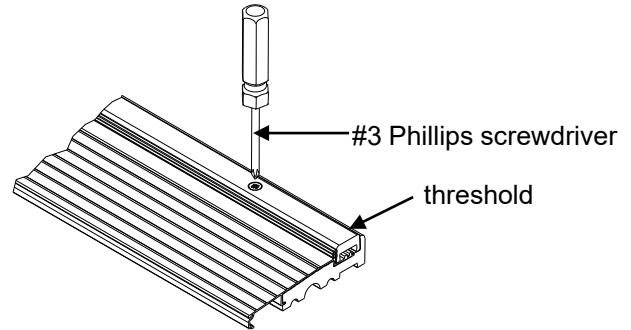

Figure 4
(In-swing only)

- 5 IMPORTANT:** For in-swing doors, install two corner seal pads (included in the installation kit) at each of the jamb bottoms of an active door per Figure 5a. For a double door system, verify that a corner seal pad is installed at the bottom of the active door side of an astragal. The corner seal pad should be tucked underneath the weatherstrip. Caulk at the intersection of the jambs, brickmolds, threshold and floor. For out-swing doors, also caulk at the intersection of the jambs, brickmolds, threshold and floor per Figure 5b.

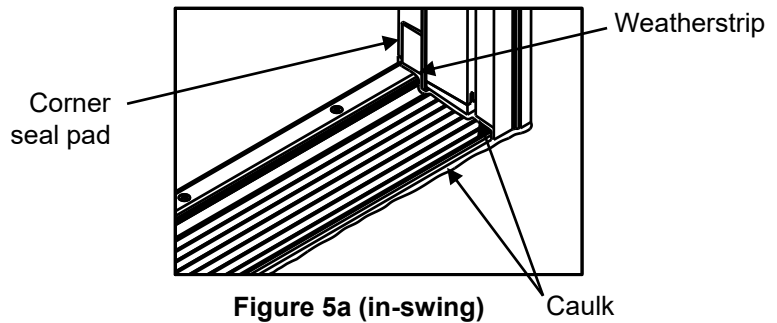

Figure 5a (in-swing)

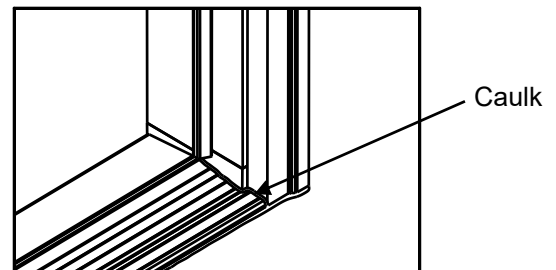

Figure 5b (out-swing)

FINISHING INSTRUCTIONS

Staining or painting an unfinished SIGNAMARK fiberglass door has never been easier. Our fiberglass door does not require special stain kits or primer. Use the same exterior stain or paint you would use for finishing your home's other trims.

Note that a tan woodgrain and unpainted smooth door must be finished within 6 months after the door is purchased. When finishing, remove the door from the frame and place door in a flat level surface off the floor. Sidelites need to be finished while attached to the frame.

Caution: Paint or stain in a well ventilated area. Keep combustible paint, stain and topcoat away from heat and flame. Keep out of reach of children.

Stain Finish

All surfaces of a tan woodgrain door are stainable. Our patented textured fiberglass door surface yields superior stain adhesion without sanding. Select a high quality water-based stain from Minwax® or Behr® or a high quality gel stain from Minwax® or Olympic®. Or, select a high quality oil-based stain from Ace®, Minwax®, or Zar®.

Before applying a stain, wipe the fiberglass door and door lite frame with a damp cloth to remove any dirt, oil, or debris. Allow the surface to fully dry before staining. Apply an even amount of stain with a brush or lint-free cloth in the direction of the wood grain as shown in Figure 6. Work the stain into the surface. Lighten stain and remove excess through wiping with a clean rag before stain dries completely. For a darker appearance, apply a second coat after first coat dries. Follow the application instructions on the stain container label. After stain has dried for at least 24 hours, apply three coats of high quality exterior grade satin or low gloss polyurethane in the direction of the wood grain. Follow the label's drying time between coats.

Important: Use polyurethane with ultraviolet (UV) inhibitors.

Paint Finish

Tan woodgrain or unpainted/pre-painted smooth fiberglass doors are paintable with most high quality oil based exterior paints. For the unpainted smooth doors, we recommend lightly sanding with 600-grit sandpaper for the best results. Before applying a paint, wipe the fiberglass door and door lite frame with a damp cloth to remove any dirt, oil, or debris. Allow the surface to fully dry before painting. Paint the door in the directions shown in Figure 6. Apply at least two coats of paint. Follow the brand's recommended drying time between coats.

Finishing Wood components

Both the pre-finished and unfinished fiberglass doors come with factory finished prime coat on the jambs and brickmolds, unless clear wood components are specified in the order. We recommend staining the clear jambs, brickmolds and other clear wood components or stainable astragals per above stain finish instructions. Apply 2 or 3 coats of exterior grade polyurethane with ultraviolet (UV) inhibitors. Lightly sand with 600-grit sandpaper between coats for smoother finish. If painting is desired over primed wood components, use quality exterior grade acrylic latex or oil-base paint. Use wood filler to putty the nail marks on the wood components before staining or painting. **Wood components must be finished within 2 weeks after installation.**

NOTE FOR STAINABLE ASTRAGAL: To protect the integrity of the wood veneer and its bonding adhesive, do not expose the astragal to oils, thinners, solvent based cleaners or similar items. **The stainable astragal should be finished prior to being installed to the door opening and exposure to the weather.**

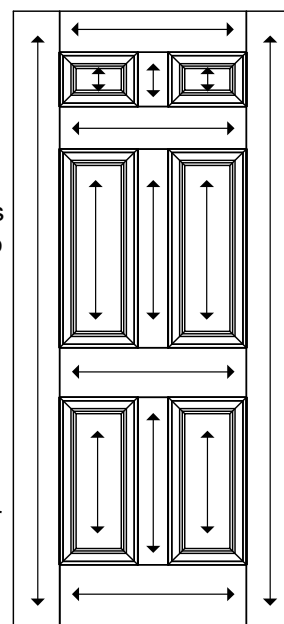

Figure 6

CARE AND MAINTENANCE

Finished Woodgrain Doors: Over time, harsh weathering will degrade even the best fiberglass finish. We recommend reapplying a UV topcoat over the existing topcoat every 2-5 years. We do not recommend stripping the factory finish topcoat. In locations of severe weather exposure, more frequent maintenance may be required. Fading, minor cracking and peeling are some initial signs of UV topcoat deterioration.

Painted Fiberglass Doors and Wood Components: Repaint your doors, jambs and brickmolds as soon as deterioration occurs. Initial signs of wear are fading, cracking, bubbling, and peeling.

Weatherstrip: Replace compression weatherstrip, door sweep, and seal pads when worn or torn.

Caulking: Just as with the finish, it is imperative that deterioration of caulking/sealant is properly maintained. Any areas of deterioration should be re-caulked based on the areas pointed out in the installation instructions (Exterior Trim to Exterior Facade, Exterior Trim to Jamb, Jamb Base to Threshold/Sill). Note: All SIGNAMARK fiberglass door lite frames come pre-caulked from the factory. The excess sealant on the door lite is normal and does not indicate a defective glazing. In some cases, over time, you may experience excess caulking/sealant ooze around the lite frame. In most cases this happens during extreme heat buildup or when the door is exposed to direct sunlight. The excess sealant on the glass can be removed by carefully scoring the excess sealant with a razor blade and peeling it off. The excess sealant on the glass side may be better removed with the blade after scoring. However, for the sealant on the finish side, the sealant should be removed without using the blade after the initial scoring around the perimeter of the frame.

Door Lite Plugs: Every door with a lite comes with enough plugs to fill all screw holes. All screw plugs should have a tight fit when installing to keep from falling out. To install screw plugs, line up screw plug with hole and insert at a slight angle to get started. In some cases, you may be able to push the plug into place with hand. In most cases, you will need to take a small round head hammer and lightly tap into place or take the handle part of a screwdriver and tap into place with a hammer. If it seems that the screw plugs are too tight to fit into the plug holes, place the screw plug packet in a freezer for about an hour prior to installing or slightly sand or file bottom side of the plug to help plug get started in the plug hole.

Thermal Bowing: In some areas with temperature fluctuations, your door may experience signs of bowing over a period of days. This is typically due to the temperature difference between the exterior and interior part of the home. In most cases the door should return back to its normal position. This is also common during the first couple of weeks after the door is installed while the door becomes acclimated to the opening. However, in areas or conditions of extreme temperature exposure on the door, some permanent bowing can be expected. In the areas of extreme temperature exposure, the effect of the temperature on the door can be reduced by following some recommendations listed below.

Door Exposure and Protection: Doors protected by the elements will obviously need less maintenance and re-finishing vs. doors fully exposed to the elements. So, overhangs will help provide long lasting protection to your entryway along with reduced maintenance.

Color Choice: As with overhangs, door colors may help reduce periodic maintenance and help with the door performance, especially in areas where doors receive an extreme amount of sun without protection. Dark colors will absorb more heat than the light colors. So, if a door is absorbing a lot of heat or has constant sun exposure, it is more likely to have UV topcoat deterioration, color fading, and even issues with warping due to differential temperature. Light colors in these situations will help reduce the amount of heat absorption and help prolong the life of the door and reduce the overall maintenance.

Storm Doors: Our doors are energy efficient and storm door protection is not necessary. If purchasing a storm door, keep in mind that it should be ventilated to help reduce the amount of heat buildup. Full View non-ventilated storm doors in areas where no overhang and constant sun exposure is present will most likely lead to accelerated issues pointed out above due to the extreme heat (UV deterioration, color fading, warping, caulk/sealant oozing).

Anchoring Detail (For Florida and Texas, see page 8 for installation drawings)

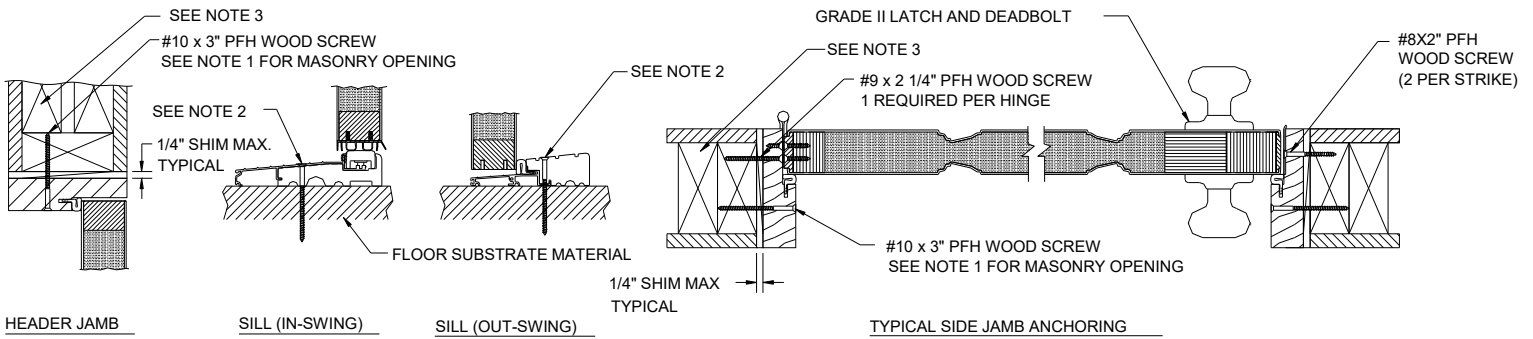
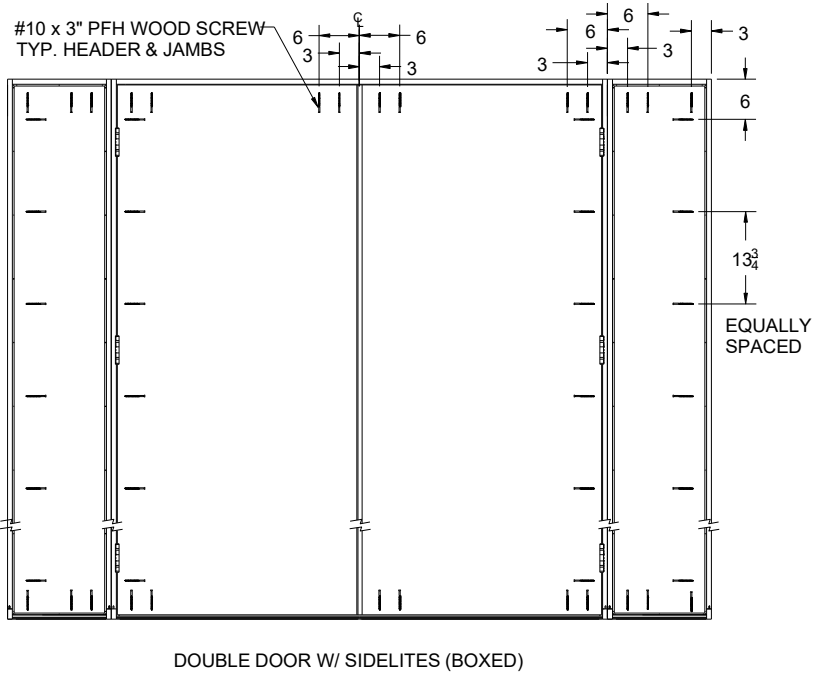
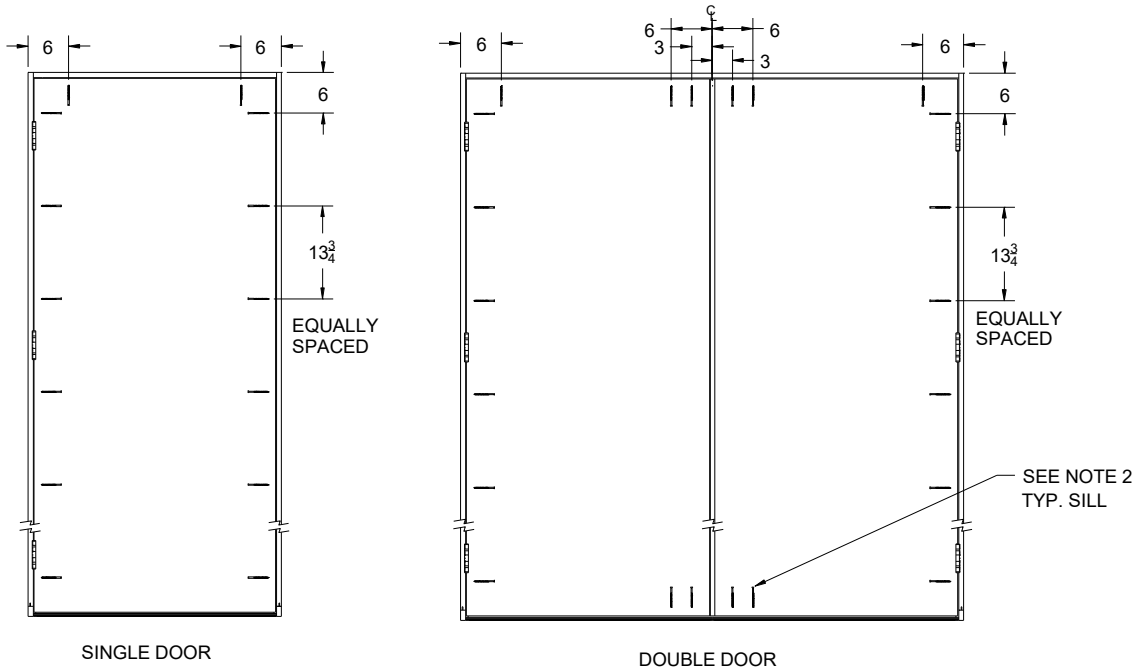

NOTE:

1. FOR MASONRY OPENING, USE 3/16" x 3 3/4" TAPCON CONCRETE SCREWS.
2. FOR WOODEN SUBSTRATE MATERIAL, USE #10 X 3" PHILLIPS FLATHEAD(PFH) WOOD SCREWS. FOR MASONRY SUBSTRATE MATERIAL, USE 3/16" X 3" TAPCON CONCRETE SCREWS. 3/16" TAPCON SCREWS REQUIRE A MINIMUM 2" CLEARANCE TO MASONRY EDGES.
3. 2X ("2 BY") FRAMING OF 2X4 OR GREATER IS TO BE USED. CONSULT ENGINEER OR ARCHITECT OF RECORD CONCERNING FASTENING THE PREHUNG UNIT TO THE REST OF THE BUILDING STRUCTURE.
4. USE THE #8, #9 AND #10 WOOD SCREWS SPECIFIED IN THE ANCHORING DETAILS. ANY DEVIATION MAY AFFECT THE STRUCTURAL PERFORMANCE.

Anchoring Detail (For Florida and Texas, see page 8 for installation drawings)

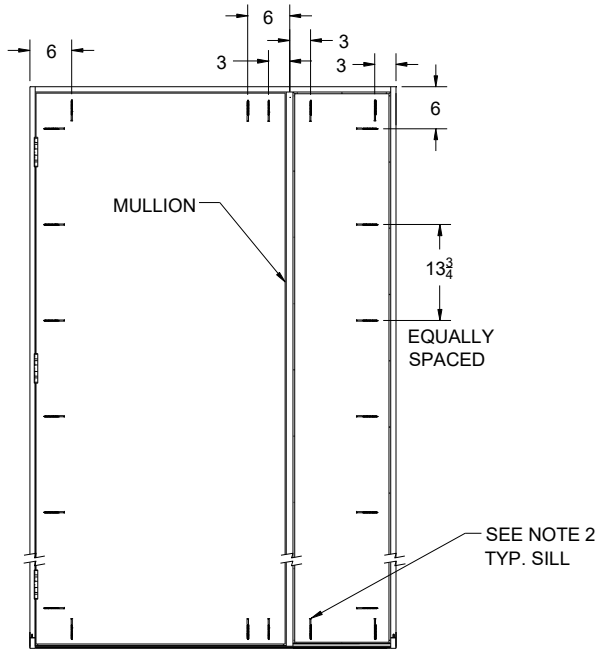

SINGLE DOOR W/ SIDELITE (CHS)

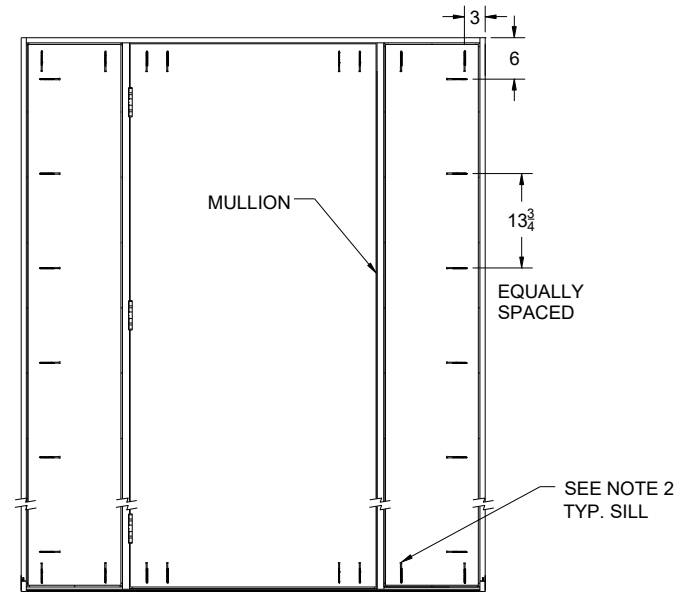

SINGLE DOOR W/ SIDELITES (CHS)

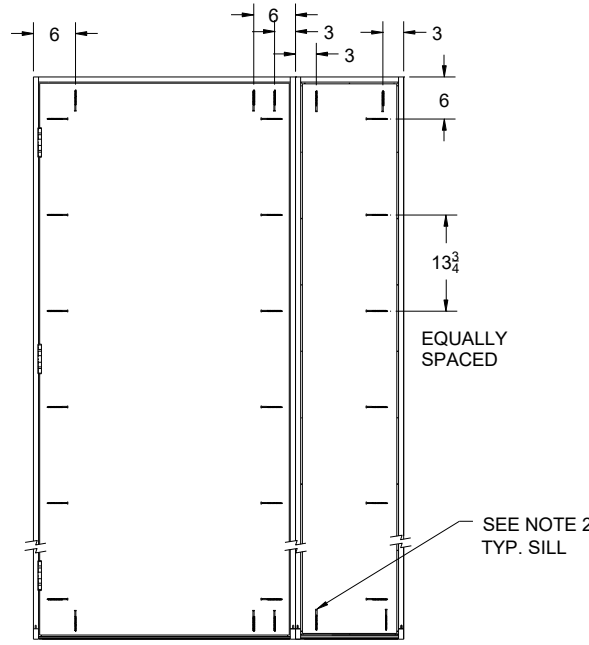

SINGLE DOOR W/ SIDELITE (BOXED)

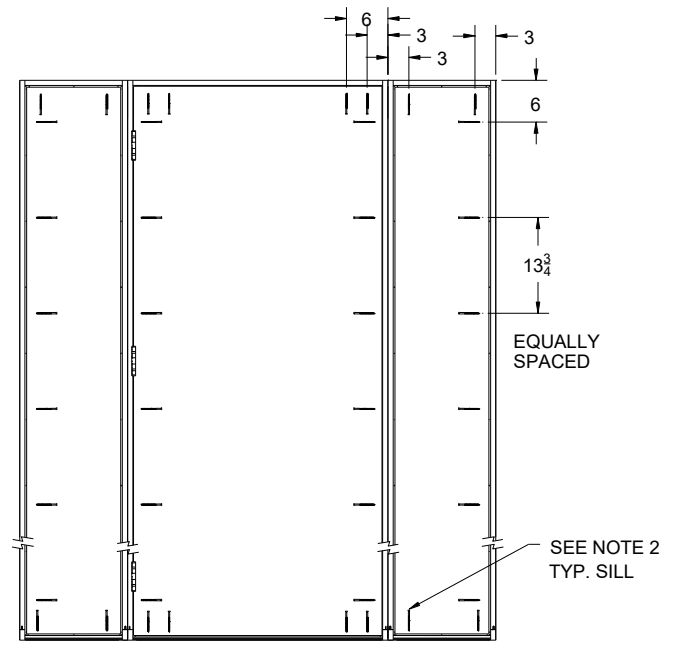

SINGLE DOOR W/ SIDELITES (BOXED)

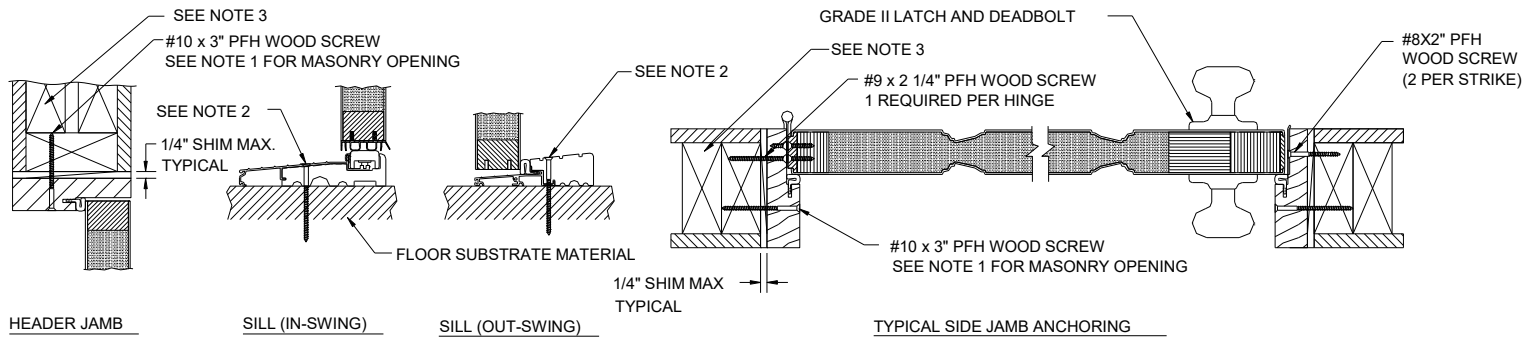

- NOTE:
1. FOR MASONRY OPENING, USE 3/16" x 3 3/4" TAPCON CONCRETE SCREWS.
 2. FOR WOODEN SUBSTRATE MATERIAL, USE #10 X 3" PHILLIPS FLATHEAD(PFH) WOOD SCREWS. FOR MASONRY SUBSTRATE MATERIAL, USE 3/16" X 3" TAPCON CONCRETE SCREWS. 3/16" TAPCON SCREWS REQUIRE A MINIMUM 2" CLEARANCE TO MASONRY EDGES.
 3. 2X ("2 BY") FRAMING OF 2X4 OR GREATER IS TO BE USED. CONSULT ENGINEER OR ARCHITECT OF RECORD CONCERNING FASTENING THE PREHUNG UNIT TO THE REST OF THE BUILDING STRUCTURE.
 4. USE THE #8, #9 AND #10 WOOD SCREWS SPECIFIED IN THE ANCHORING DETAILS. ANY DEVIATION MAY AFFECT THE STRUCTURAL PERFORMANCE.

Installation drawings for Florida and Texas

Installation drawings for Florida and Texas may be downloaded from the SIGNAMARK website.

Go to www.signamark.com , roll over the RESOURCES menu and find the Performance Data section for a listing of installation drawings for each area. Note that some areas require that these drawings to be available at the time of inspection. So, print and save these drawings for the inspector. Please make sure that the door unit is installed as specified in the drawing.

If you do not have access to the internet, please call customer service (1-800-803-8182) and request a copy of the installation drawing.

Drawings to Use

- For Florida customers who live in Dade/Broward County or High Velocity Hurricane Zone (HVHZ) areas, please use Florida state approval drawings that complies with HVHZ. All other Non-HVHZ Florida customers may use either the Florida state approved Non-HVHZ or HVHZ installation drawing.
- For some coastal states, Florida state approvals are accepted. In that case, please download either Non-HVHZ or HVHZ installation drawing according to the requirement and install the door unit as specified in the drawing.